



SURESPAN

www.surespancovers.com

Aluminium Stair Unit

Approval Drawing

BS4211:2005 + A1 2008

Ref No.

PRODUCT SPECIFICATION

CODE: SHP/F/A

HANDRAIL

- Height: 1100mm above surface of decking
- Top rail: 35mm diameter tube
- Midrail: 35mm diameter tube
- All internal fixings to be dome
- Handrails fitted to both sides of stairs & platform
- Finish: Mill finish aluminium

STAIR

- Stiles: 152 x 9.5 Aluminium flat bar
- Tread Dimensions (h x w x d): 35 x 600 x 250mm (nominal)
- Tread construction: Folded Aluminium Chequer plate
- Fixings in stainless steel A4 grade
- Finish: Mill finish aluminium
- Guardrail height: 950mm

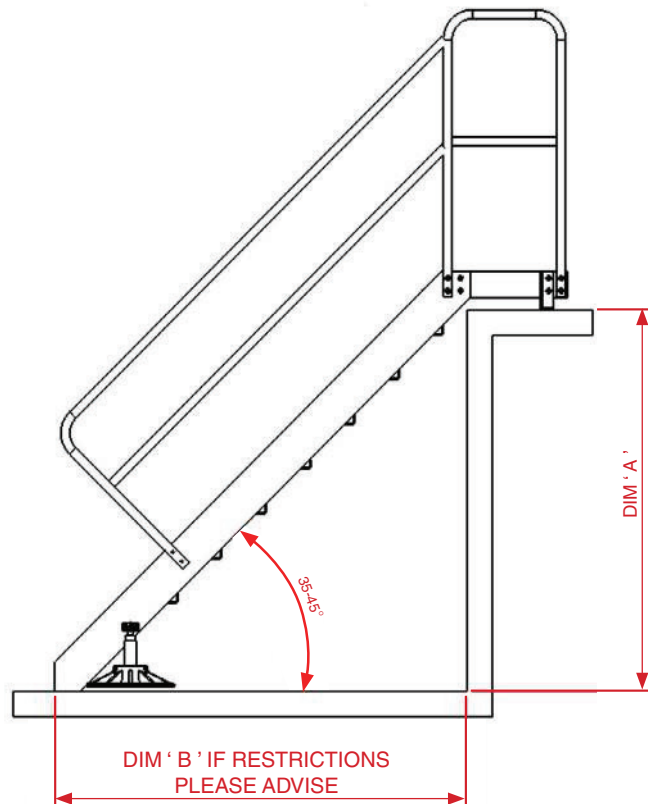
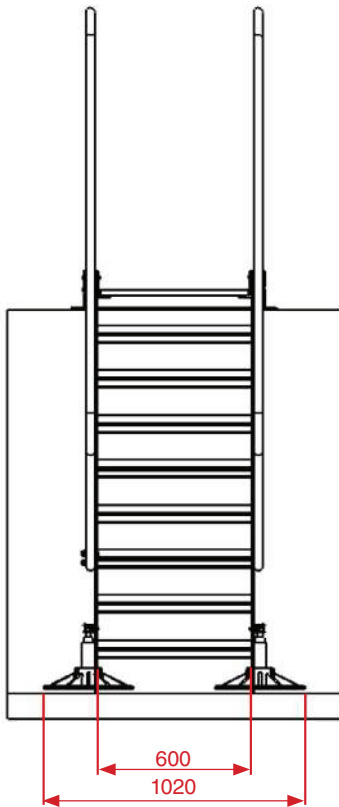

Customer name:

Dimension ' B '

Project title:

Date:

Order number:

Dimension ' A '

Comments:

I can confirm the above information is correct and that our order shall be manufactured to these sizes.

Signed:

